

IM-982 Panel PC 8"



Product information

IM-982 Panel PC 8"

The Panel PC is designed for installation in IM-982 Front panels designed. Based on the low Power Intel Atom processor.

The IM-982 is the basic configuration an economical and technically efficient strong solution dar.

The scope of the IM-982 is robust tasks in automation engineering design.

All connections of the Panel PC IM-982 where there the on the back. Installation done through the housing which M4 threaded bolt.

By default, included with the Ethernet and four USB ports.

Optional, the Panel PC can include with 12 digital IO's, a CAN bus master / Slave interface and four PCI slots be upgraded.

The Panel PC is running with, among others Standard operating systems from Microsoft, Linux or SCO.

Features

- 1,1 GHz Low Power CPU
1 GB RAM, Ethernet 100,
6 x USB 2.0
- 8" TFT LCD 1024 x 768 XGA VGA
Led Lighting
- Flash memory to 2 GB
- 24 V DC voltage
- Temperature range of
10°C up to +50°C
- High reliability and
life cycle
- Front IP 54, Rear IP20 fanless
- Durable aluminum housing
- Compact dimensions
- Weight 1.1 kg

Optional

- Touchpanel
- SSD fixed hard disk
- SD or CF Card
- 12 digital IO's
- 1, 2 or 4 PCIe slots
- Local IO's
- CAN_OPEN fieldbus master / slave
- 1.6 GHz low power CPU
- Audio Intel High Definition Audio
- Front foil with up to 24 keys + 4 Led

Mechanical dimension:

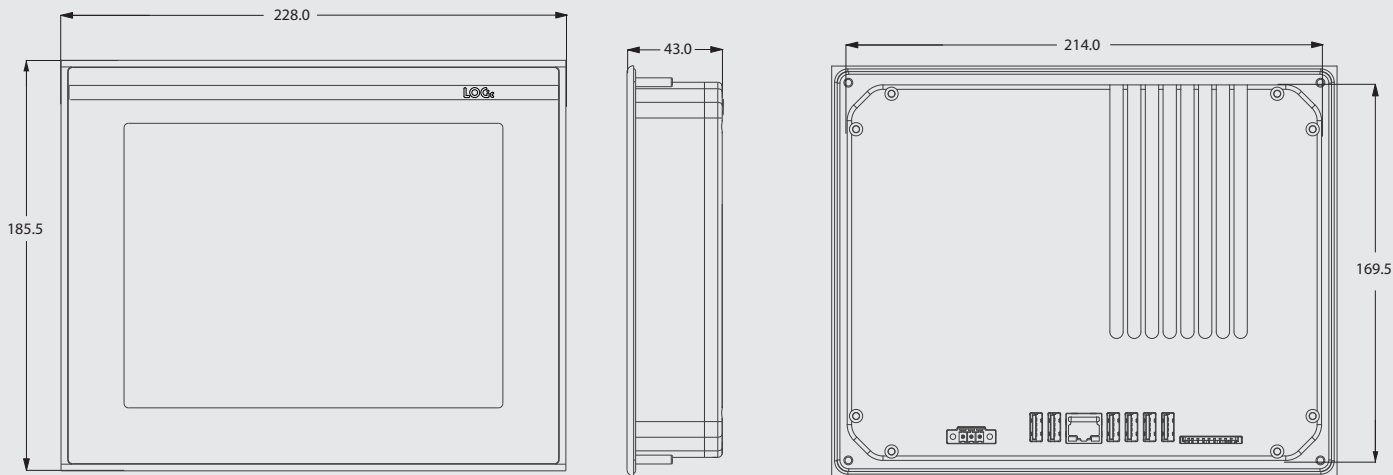

Technical data:

Data IM-982	
Supply	24 VDC +15% -30%
Switch on current	max. 0,1 A
Current consumption	min. 40 mA
Inputpower	8 W
CPU	1,1 GHz, opt. 1,6 GHz
RAM	up to 1 GB
LCD	8" XGA 1024 x 768
Intensity	560 cd / m ² LED
Flash memory	up to 2 GB
Boot Device	Flash SSD
Processor architectur	ATOM Intel
Ambiente temperature	10°C bis 50°C
Reliability	self diagnosis
Connections	
USB	6 x USB 2.0
Ethnernet	RJ45 100MBit
SO / MMC - Card	up to 128 GB
Keyboard / Mouse	USB
Mechanical data	
Protection	IP54 front
Dimension	228 x 185.5 x 43 mm
Weight	1.1 kg
Option	
Digital IO	12 digital IO's
Fieldbus	CAN_Open DSP 402
Local IO's	diverse
PCIe	4
Sound	Intel High Definition Audio

Electrical connections:

For the electrical connections on the IM-982 Panel are diverse connetions available.

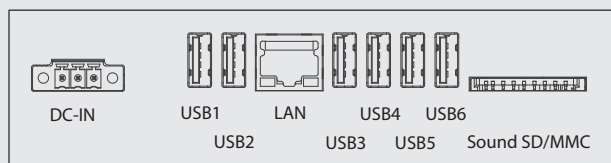

The IM-982 Panel PC runs with Windows operating systems, XP, CE, 2000, and on Linux. About LAN Interface can connect the PC to a network and through the 6 USB ports, it is as no longer necessary, external hardware, such as a USB hub to connect.

Subject to change without notice.